

Mounting Installation Instructions

ZG-JSL(A)

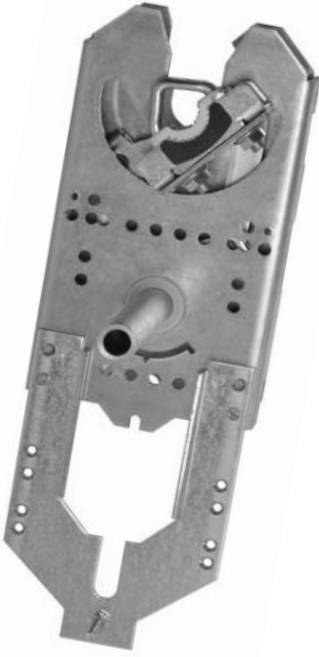

ZG-JSL Kit Includes:

- Jackshaft Linkage
- "L" Shaped Anti-Rotation Bracket
- Adapter Plate for Anti-Rotation Bracket
- Actuator Anti-Rotation Plate
- Hardware Bag (screws, V-bolt, nuts, clamp insert and insert holder)
- Instruction Sheet

General Information

Preliminary Steps

1. Verify all the parts listed before installing the linkage.
2. Choose an actuator from one of the series listed below. There is a torque reduction when using the ZG-JSL linkage. Verify application requirements before use.

Actuator*	Torque Reduction
AFX Series	166 in-lbs
AF Series	123 in-lbs
NFX Series	87 in-lbs
LF Series	33 in-lbs
NMX Series	87 in-lbs
AMX Series	166 in-lbs

* GM/GK Series pending approval

3. Determine proper location to install the linkage onto the damper's jackshaft. Verify that there are no obstructions and that the damper blades do not collide with the linkage. If available, refer to the damper manufacturer's dimensional drawings; the dimensions of the shaft bearings and damper blades are usually published.
- 4a. Verify the diameter of the jackshaft. The maximum diameter this linkage can accommodate is 1.05". The linkage will come factory pre-set for 1" shafts.
- 4b. The linkage comes with a reversible metal insert for 1/2" and 3/4" shafts.

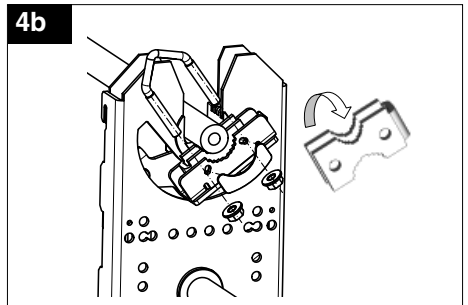

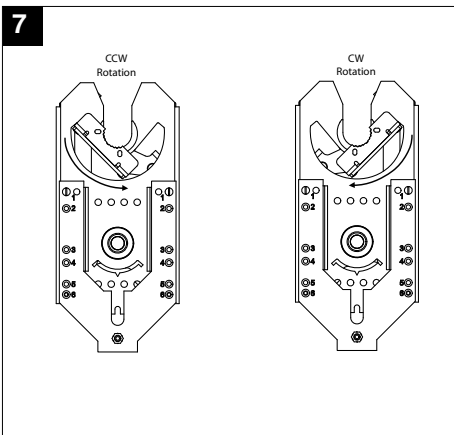
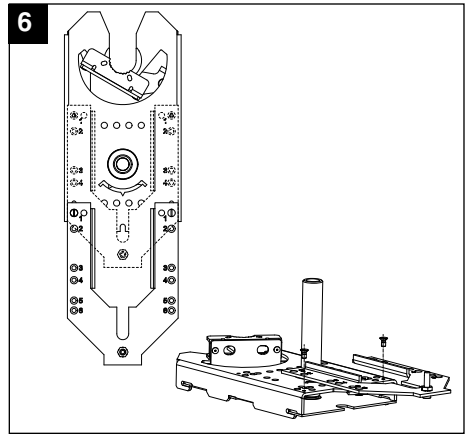
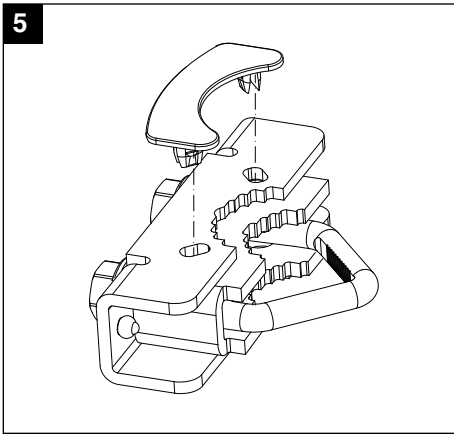

Hole Designation #	Belimo Actuator Series
1	AF Series
2	AFX / NFX Series
3	GM Series (Pending Approval)
4	LF Series
5	AM Series
6	NM Series

- Once the insert is turned to the desired shaft size, install the plastic insert holder as shown.
- After selecting the actuator, the anti-rotation plate will need to be moved. Loosen the two metal screws. Line up the two threaded holes on the base plate with the corresponding holes of the actuator. Holes are clearly marked by a numeric digit on the anti-rotation plate. See chart for hole designations.

- Verify that the opened-ended shaft of the linkage is in the correct position. Almost all dampers operated by jackshafts open when the jackshaft is turned in the counter-clockwise (CCW) direction. Make sure the shaft is turned completely clockwise (CW). For CW rotation, turn the shaft all the way CCW (or to the right). Verify the position, by the clamp itself or the small indicator below the shaft.

Note: Find a suitable location on the jackshaft to install the linkage. Either end of the jackshaft will work, as long as it does not interfere with the bearing.

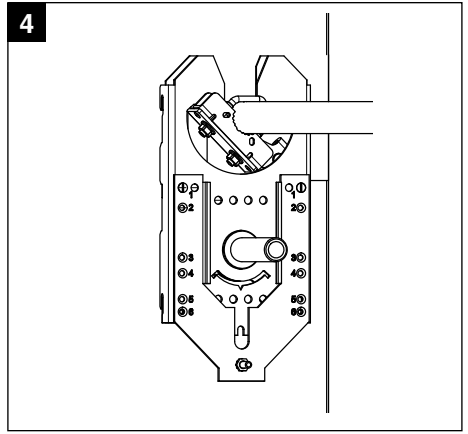
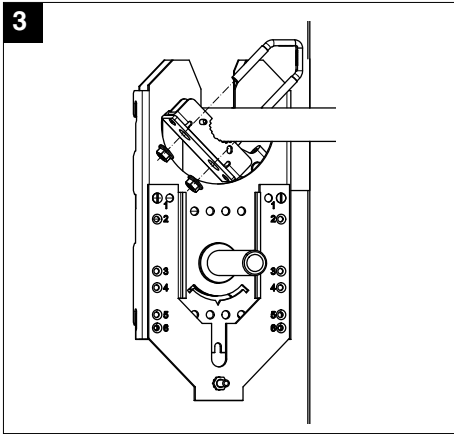
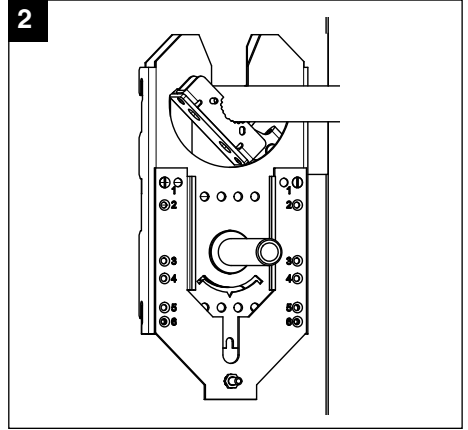
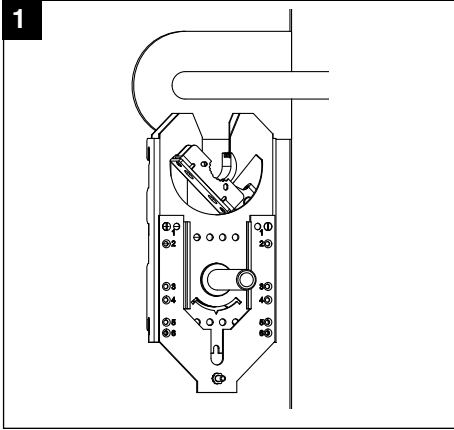

Standard Mounting

1. Place the open end of the linkage underneath the jackshaft.
2. Slip the jackshaft into the open end until it meets the clamp.
3. Holding the linkage in position, insert the supplied V-bolt from the other end.
4. Hand tighten nuts only to hold the clamp in position and prevent it from rotating.

Installation Instructions

Quick-Mount Visual Instruction for Mechanical Installation

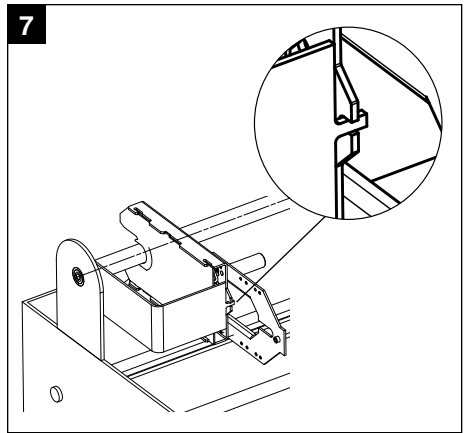
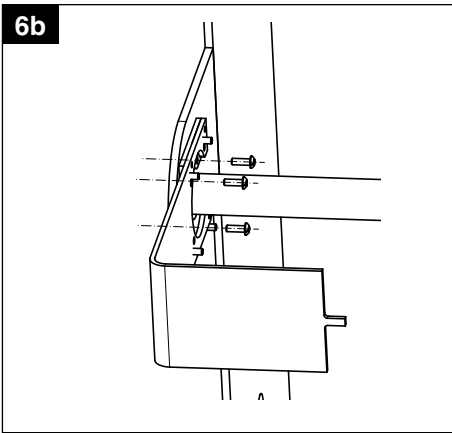
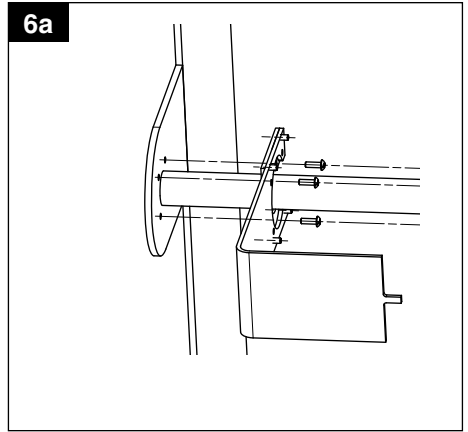
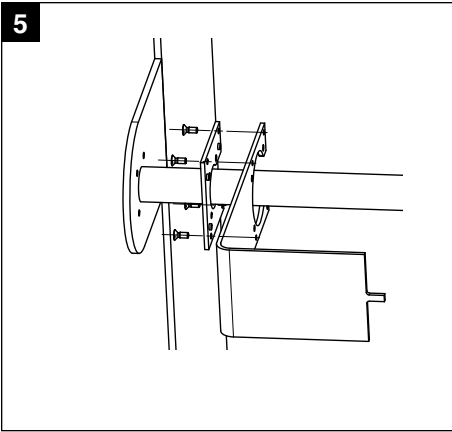

5. With the linkage in place, secure it to the damper frame with the anti-rotation "L" bracket. The bracket can rotate to any angle. If necessary, use the additional adapter plate for smaller bearings. Screw the adapter plate into the "L" bracket, as shown, with the flat head screws.
6. Install the "L" bracket with or without the adapter plate to the shaft bearing bracket, using the self tapping screws.

Note: Some adjustments may be needed to properly align with the anti-rotation bracket. This involves loosening the two nuts holding the V-bolt in place. This allows the linkage to slide on the jackshaft, enabling the tab of the anti-rotation bracket to be properly attached.

7. With the "L" bracket attached, slide the ZG-JSL linkage over until the tab on the bracket meets up with the slot on the linkage.

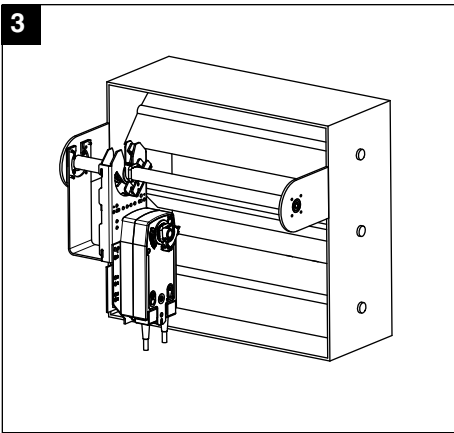
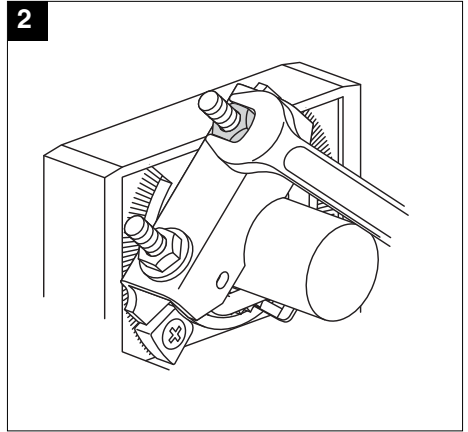
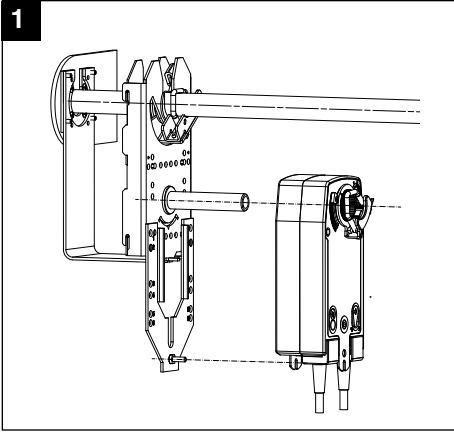

Standard Actuator Mounting

1. With the linkage set in either CW or CCW format, install the actuator with the V-bolt and clamp. Align the screw on the anti-rotation bracket with the slot of the Belimo actuator as shown. Assembling an actuator onto the linkage can be done before or after the linkage is installed onto the jackshaft. It is recommended to assemble the actuator onto the linkage first. Use caution when installing the linkage with the actuator because of the added weight and handling.
2. Once the actuator is in place, tighten the nuts. Ensure even tightening to prevent slippage.
3. Ensure all nuts are properly tightened and secured. The linkage and actuator are now installed on the damper shaft.

Note: Refer to the damper manufacturers recommendations before tandem mounting ZG-JSL linkages.

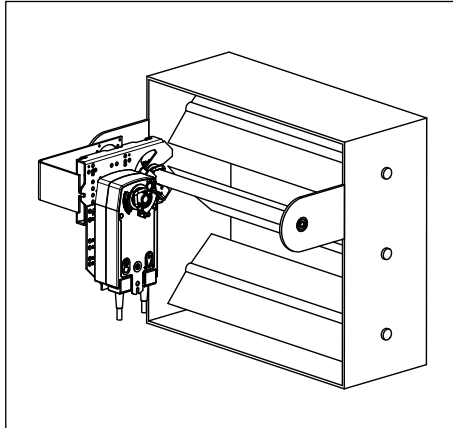
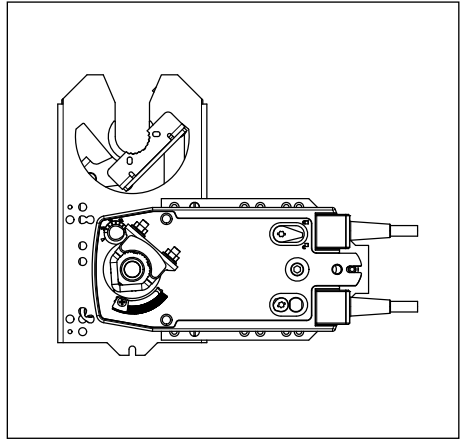
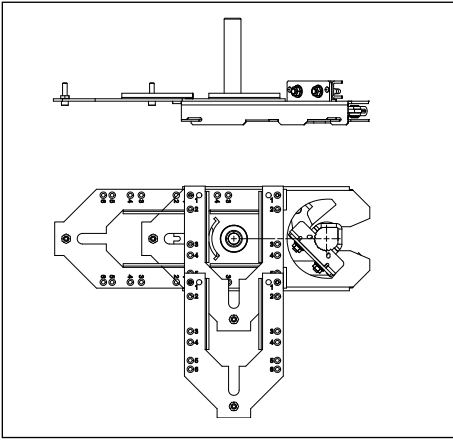

Space Saving Configurations

The linkage can also be configured to have the actuator mounted horizontally.

For this configuration, loosen the two screws holding the actuator anti-rotation plate to the linkage. Reposition it ± 90 degrees from its original position. Reattach the plate using the two corresponding threaded holes on the base plate.

The actuator anti-rotation plate can be fastened from either side and as shown. The location of the holes is determined by the actuator.

Installation Instructions

Actuator Dimensions

Old Generation AF Dimensions (inches [mm])

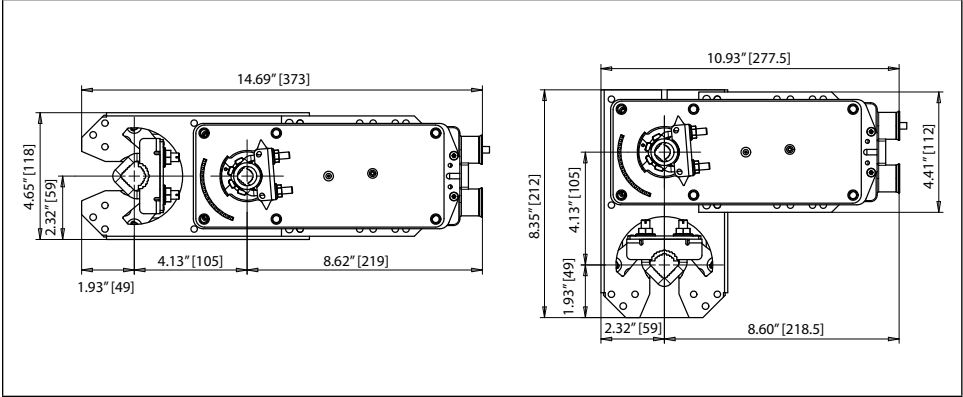

New Generation AF/NF Dimensions (inches [mm])

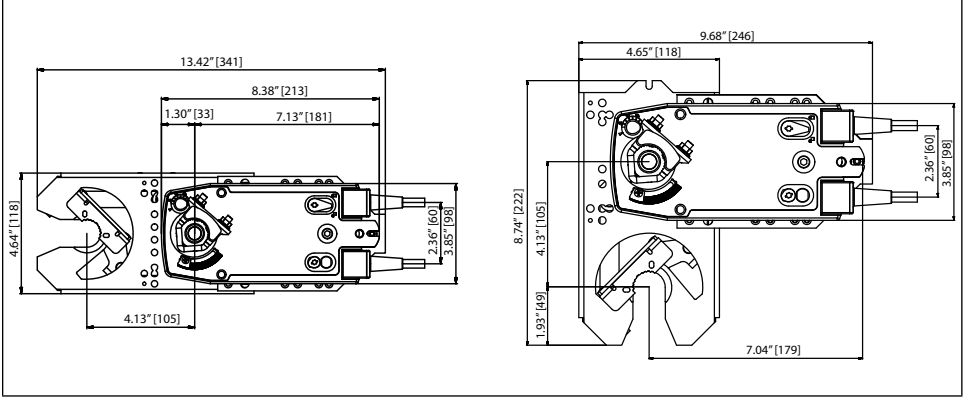

RETRO  **FIT**®
SOLUTIONS BY BELIMO

Belimo worldwide: www.belimo.com

BELIMO Americas

USA Locations, 43 Old Ridgebury Road, Danbury, CT 06810
Tel. 800-543-9038, Fax 800-228-8283, marketing@us.belimo.com

1049 Fortunado Loop, Sparks, NV 89436
Tel. 800-987-9042, Fax 800-987-8875, marketing@us.belimo.com

Canada Locations, 14/16 – 5716 Coopers Avenue, Mississauga, Ontario L4Z 2E8
Tel. 866-805-7089, Fax 905-712-3124, marketing@us.belimo.com

Latin America and The Caribbean Customer Service
Tel. 203-791-8396, Fax 203-791-9139, marketing@us.belimo.com